

INSTRUCTION & MAINTENANCE MANUAL

TECHTROL MAGNETIC FLOAT OPERATED PIVOTED LEVEL SWITCH "FPS"



Innovating Level Controls since 1984

Introduction :

It is an economical, maintenance free and reliable device used for high, low or intermediate point level switching. It is ideal for tanks with inaccessible tops or bottoms and where insertion depths of top mounted models are exceeded.

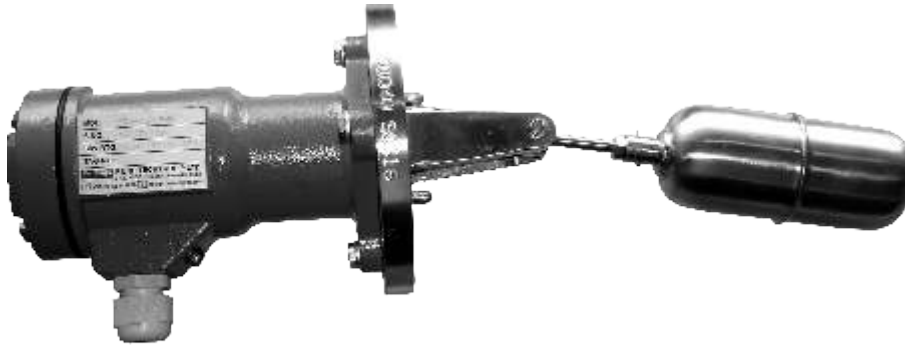

Construction and Operation (Fig. 1) :

Compact and rugged construction consisting of a free moving pivoted float assembly and a switch enclosure in nonmagnetic material to achieve undisturbed magnetic flux. It employs dual magnets, one carried by the float arm, other by the contact carriers housed in switch enclosure. A change in liquid level brings the like poles of dual magnets opposite to each other and resulting repulsion force ensures a changeover of contacts with snap action. The magnetic transmission is glandless, leaving no scope for leakages from vessel into switch housing. These switches are manufactured in various materials, enclosures and special features to suit broad range of media / applications. They are designed to provide high repeatability and to minimise effects of shock, vibration and pressure.

Fig. 1: Construction

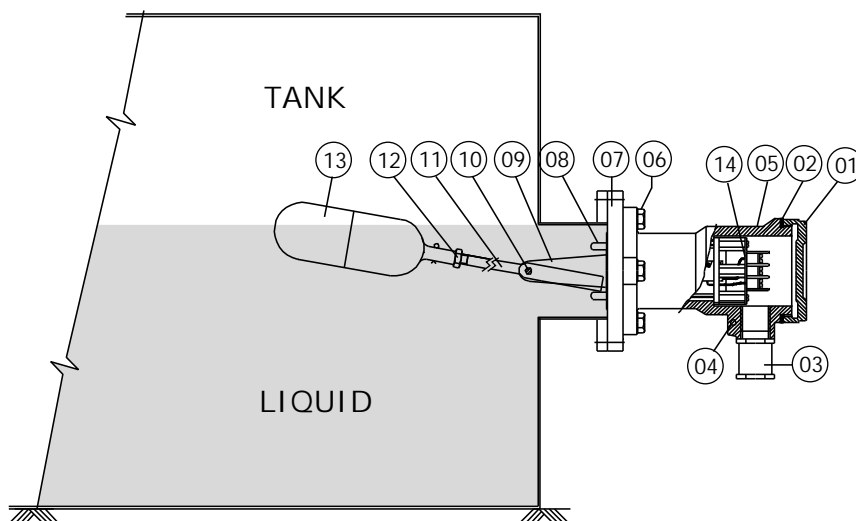

- 01) TERMINAL CAP
- 02) GASKET
- 03) CONDUIT CONNECTION
- 04) EARTHING SCREW
- 05) SWITCH HOUSING
- 06) BOLTS
- 07) PROCESS CONNECTION
- 08) STOPPER
- 09) BRACKET
- 10) PIVOT PIN
- 11) TRIM
- 12) FLOAT LOCK NUT
- 13) FLOAT
- 14) SWITCH CHASSIS

Pre-Installation Procedure :

- Select continuity range on multimeter and connect its probes to P and NO Contact of level switch.
- Move the float manually upwards from its 'Normal Condition' to 'Alarm Condition' and ensure that 'NO' contacts become 'NC' by observing continuity on the multimeter.
- Repeat Select continuity range on multimeter and connect its probes to P and NC contacts of level switch.
- Move the float manually upwards from its 'Normal Condition' to 'Alarm condition' and ensure that 'NC' contacts become 'NO' by observing continuity on the multimeter.

Installation : (Fig.2)

Mounted internally or externally through a chamber. External mounting is resorted to, where space is a limiting factor or mechanical devices like stirrers operate within the tank. Besides, in applications like boilers, reaction kettles etc. with external mounting, isolating is possible for regular servicing. The switch is normally side-mounted, however for application like slurry, top installation is preferred. The switch can be wired directly "to make or break electrical circuits" of burners, heaters, motor-pumps, alarms and other such electrically operated devices.

1. Ensure that ID of mounting nozzle is greater than float diameter.
2. Select a suitable location on tank where vibrations if any are minimum.
3. Ensure that process connection of Level Switch match with those on tank.
4. Ensure counter connections provided on tank are vertical and in plumb line.
5. Ensure that C=C distance of external cage match with those on tank.
6. Ensure that in case of externally mounted version, provide separate isolation valve on tank for safety & removal of Level Switch for repairs / maintenance.
7. Provide suitable gasket between the flanges before bolting, to ensure zero leakage through joints.
8. Ensure mounting nozzle length & inside diameter must be sized correctly to allow for switch actuation at desired level.

Fig. 2 : Installation

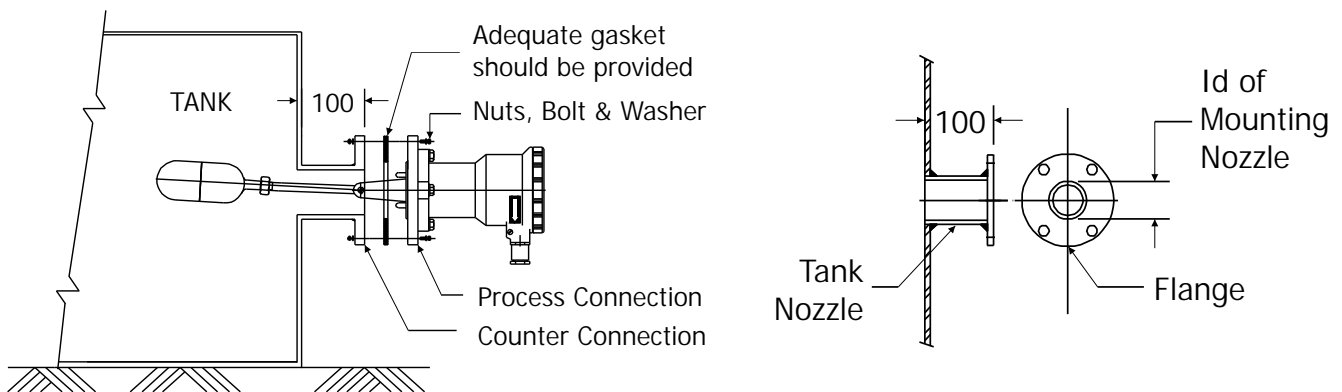

NOTE:- Distance 100 mm max. considered nozzle pipe schedule will be max. 40. If more contact factory.

Termination : (Fig. 3)

Before actually turning ON the power supply make sure that all the wiring is done correctly.

Precautions:

1. Ensure that supply voltage and current rating is as per its rated capacity. Excessive voltage / current will permanently damage the switch contacts.
2. Ensure that the switch is duly earthed.
3. Ensure use of proper cable for wiring, which should match the current rating of connected load.
4. Ensure terminal contacts are not loose.
5. Ensure that enclosure is always covered with its terminal along with gasket provided for it, to protect it from dust and weather.
6. Ensure that Level Switch should not be used for Liquids containing iron particles or other strongly magnetic material
7. Ensure when mounting switch in the side of tank, arrow on the switch enclosure must be pointing downward.

Fig. 3 : TERMINATION

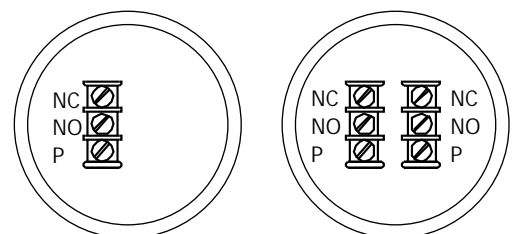

1 C/O OUTPUT

2 C/O OUTPUT

POTENTIAL FREE MICRO
SWITCH CONTACTS

CONTACT RATING 5A @ 230VAC

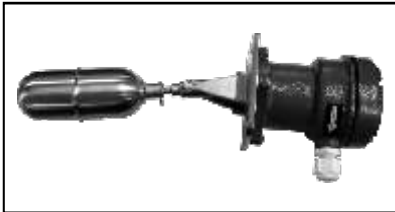
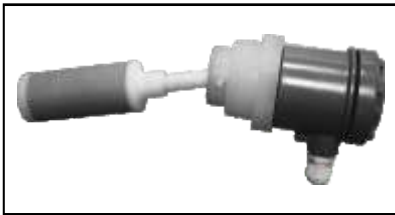
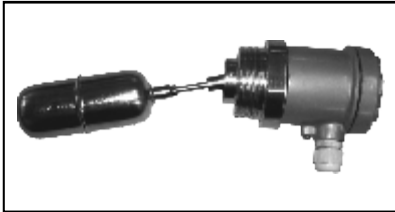

In situ Test Device - T :

It is supplied as an accessory to Magnetic Switch (FPS) to facilitate mechanical testing of electrical circuit. As such operations are checked without carrying out the emptying / filling cycle.

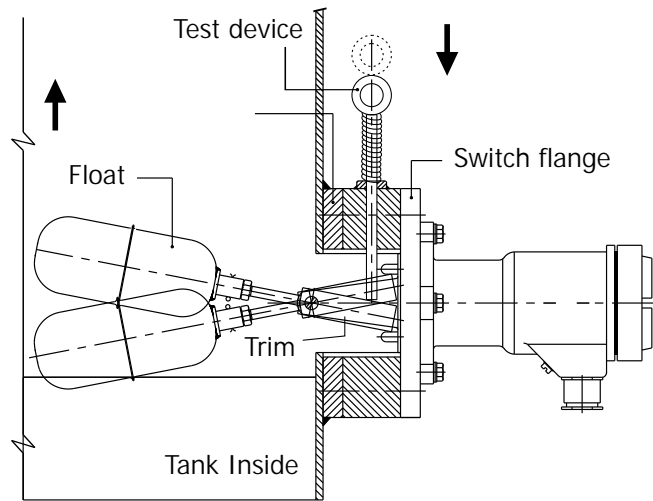

Maintenance :

- Switches must be cleaned frequently if the Liquid has high viscosity or contain floating material.
- Ensure that terminal connections are not loose.
- Ensure that contacts of switch mechanism are not pitted / oxidized due to sparking.
- Be sure the switch enclosure cover is always in place on the enclosure.
- Disconnect device from the supply ckt. before opening to prevent ignition of hazardous atmosphere.

Trouble shooting :

Problem	Cause	Solution
1. Switch is not operating	a. Float trim movement jammed.	Loosen the pivot pin.
	b. Switch burnt due to load more than its rating.	Change switch.
	c. Micro switch contacts oxidised / pitted due to sparking.	Clean contacts.
	d. Float may be damaged / Punctured.	Change float.
	e. Wiring connection is loose.	Tighten connection.
	f. Wire connection not proper.	Wire properly as specified.
	g. Liquid Sp. gravity is lesser than that specified while ordering.	Replace float to match Sp. gravity.

Non-valid Guarantee Claims : Abnormal usage, mishandling, breakage, disaster, incorrect installation and usage beyond limits of specified operating conditions / electrical parameters.

PUNE TECHTROL PVT LTD

S-18, MIDC, Bhosari, Pune - 411026. India

+91-20-66342900, 27121052

+91-20-66342998

ho@punetechtrol.com

www.punetechtrol.com



R A T E D

NSIC-CRISIL SE-1A